

# **PAREXUSA**

## Exterior Insulation and Finish System

# **Application Guide**



Always use the latest version of the Parex USA Application Guide. This guide focuses on the application techniques for Parex USA Exterior Insulation and Finish Systems (EIFS).

**INTRODUCTION:** Exterior Insulation and Finish Systems (EIFS) have been used successfully for over 50 years in the US. It is an exterior wall cladding that is light weight, flexible, durable and adds energy saving insulation to the wall. The insulation can be shaped to easily provide architectural details. There are a vast choice of finish textures and colors available. The continuous reinforced lamina over the insulation makes this a face-sealed system. Standard EIFS do not require a weather or moisture-resistive barrier behind them because they are a facesealed cladding. Windows, doors and other objects do pass through the exterior wall. Proper flashing and sealants at those penetrations effectively protect the entire assembly from exterior water penetration. All the components of the EIFS are also user and environmentally friendly. All the liquid and paste materials are water-based. This chemistry provides a vapor permeable, breathable exterior that will allow incidental water in an exterior wall assembly to easily dry out.

If a water-resistive barrier is requested by an architect or owner, or required by code behind a classic EIFS, Parex USA has several, tested, "Drainage" EIFS to choose from. One is designed for use with Light Commercial and Residential (LCR) construction that typically uses wood framing and sheathing. The other is designed for commercial construction that typically uses steel framing with a noncombustible gypsum or cement based sheathing. These Commerical Drainage EIFS are installed exactly the same as the Standard Systems. The difference is that the Commerical Drainage Systems require additional materials and application steps on the substrate and rough openings prior to the actual EIFS installation.

This guide begins with a list of products that will be used for various segments of the three systems outlined. The second section of the guide covers General Installation Requirements. The third section describes the application of Standard EIFS from insulation board attachment through application of finish and sealants. The fourth section covers the treatment of the substrate and rough openings. The fifth section covers the substrate and rough opening treatments required for the Commercial Drainage EIFS.



**STANDARD EIF SYSTEM**

Adhesively attached, standard insulation board, using vertical ribbons of Parex USA basecoat & adhesive over an approved substrate.



**LIGHT COMMERCIAL/RESIDENTIAL (LCR)  
DRAINAGE EIFS**

Mechanically attached, standard flat insulation board with a water-resistive barrier incorporating in itself a means of drainage as a secondary weather barrier and drainage plane.

**OPTIONS:**

LCR - DM: Mechanically attached, standard flat insulation board with any code compliant water-resistive barrier and a drainage mat.

LCR - GX: Mechanically attached, grooved insulation board with any code compliant water-resistive barrier.

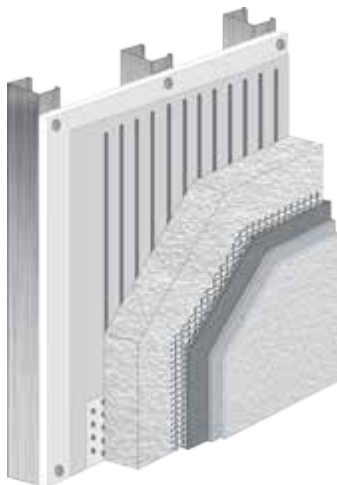

**COMMERCIAL DRAINAGE EIFS**

Adhesively attached, standard flat insulation board, using vertical ribbons of adhesive bonded to Parex USA WeatherSeal installed over an approved substrate.

**OPTION:**

GX: Adhesively attached grooved insulation board bonded to Parex USA WeatherSeal installed over an approved substrate.

**SYSTEMS AND PRODUCTS CROSS REFERENCE GUIDE**

STANDARD EIFS SYSTEMS	Parex Standard / Optimum System
	TeifsFlex
	LaHabra Insul-Flex® Standard System
	El Rey Insul-Flex® Standard System

MECHANICALLY FASTENED EIFS over a Water-Resistive Barrier	Parex WaterMaster LCR / Optimum WaterMaster LCR
	TeifsPermady
	LaHabra Insul-Flex WaterMaster LCR
	El Rey Insul-Flex WaterMaster LCR

COMMERCIAL DRAINAGE EIFS on Parex USA WeatherSeal	Parex Standard WaterMaster / Optimum WaterMaster System
	TeifsWeathertight VNT
	LaHabra Insul-Flex® WaterMaster System
	El Rey Insul-Flex® WaterMaster System

PRODUCT TYPE		BRAND			
		Parex	Teifs	LaHabra	El Rey
Water-Resistive Barrier Coating	Spray & Roll-On	Parex USA WeatherSeal Spray & Roll-On			
	Trowel-On	Parex USA WeatherSeal Trowel-On			
	Vapor Retarder	Parex USA WeatherBlock			

Adhesive Only	Non Cementitious	303 Sheathing Adhesive	Adheeze	Sheathing Adhesive	
Basecoats & Adhesives	Cementitious-Acrylic	121 (wet) 121 Optimum Wet	Teifs Base Teifs Base Optimum	Insul-Bond Wet	
	Cementitious Dry Bag	121 Dry 121 Optimum Dry 121 HI 121 Cool	TeifsBase DB Teifs Dry Base Optimum	Insul-Bond Dry	Insul-Bond P
	Non Cementitious	Quick Base in a Box ABC N -1	Quick Base in a Box TeifsStructure (Base only)	Quick Base in a Box	Quick Base in a Box
	Waterproof Basecoat	Parex USA WeatherDry			

Primer	Smooth	Parex USA Primer			
	Sanded	Variance VariPrime Sanded			

Finishes	Acrylic	DPR Acrylic Finish	DPR Acrylic Finish	Perma-Finish	Perma-Flex DPR
		DPR Optimum	TeifsFlex		
	Dry	Parex USA Dry-Tex			
	Specialty	Parex USA Variance Finishes (excluding Aged Limestone)			
	Elastomeric	e-Lastic Ultra e-Lastic	Teifs e-Lastic	Perma-Lastic	Perma-Flex Lastic
	Hydrophobic/Photocatalytic	AquaSol			

\* Parex USA products may be used with all brands

## Table of Contents

Products	1
General Installation Requirements	3
The Application of Standard System	4
The Application of Mechancially Fastened EIFS System	18
The Application of Commercial Drainage EIFS System	22



## 1. PRODUCTS

Parex USA has developed a wide range of products to meet the physical and performance conditions of most projects. For a more detailed description of these products, please review our published Product Data Sheets and Safety Data Sheets (SDS).

### Basecoats & Adhesives

#### Cementitious

*Uses:* As basecoats over EPS. As masonry levelers, adhesives for adhering EPS to masonry, exterior grade gypsum sheathing and glass mat gypsum sheathing.

**Cementitious-Acrylic Basecoat & Adhesive**, pail products mixed with Type I or I-II Portland cement in a ratio of 1 part Basecoat & Adhesive to 1 part cement by weight.

**Dry Basecoat & Adhesive**, bag products, factory blended cementitious dry powder that only requires the addition of water.

#### Waterproof Basecoat

**WeatherDry**, pail product mixed with type I or I-II Portland cement in a ratio of 2 parts WeatherDry to 1 part cement by weight.

*Uses:* Waterproof basecoat designed to protect sloped surfaces of rigid insulation boards.

#### Non-Cementitious

**100% Acrylic Basecoat & Adhesive**, are ready mixed 100% acrylic polymer based products. Do not mix this product with cement.

#### Adhesives Only

**Sheathing Adhesive**, pail product, adhesive for applying EPS to wood-based sheathings, exterior grade gypsum sheathing and glass mat gypsum sheathing.

#### Parex USA Reinforcing Mesh

**352 Adhesive Mesh, 4.5 oz.**, fiberglass, self-adhesive mesh. *Uses:* For complex architectural details, not for use on full walls.

**355 Standard Mesh, 4.5 oz.**, alkali resistant glass fiber reinforcing mesh.

*Uses:* Embedded into basecoat for typical application requirements.

**355.48 Long Standard, 4.5 oz., 48in.**, alkali resistant glass fiber reinforcing mesh.

*Uses:* Embedded into basecoat for typical application requirements.

**356 Detail Mesh, 4.5 oz.**, highly flexible reinforcing mesh.

*Uses:* For backwrapping and fabricating special shapes or contours, for double meshing corners.

**357 Corner Mesh, 7.2 oz.**, heavy duty, high tensile strength, mesh, specially folded.

*Uses:* Embedded in basecoat for application at outside corners only.

**358.10 Intermediate Impact Mesh, 12 oz.**, high tensile strength, glass fiber reinforcing mesh.

*Uses:* Embedded in primary layer of basecoat prior to additional mesh application to obtain medium impact level as defined by ASTM E2486.

**358.14 High Impact Mesh, 15 oz.**, high tensile strength glass fiber mesh.

*Uses:* Embedded in primary layer of basecoat prior to additional 355 Standard Mesh application to obtain high impact protection as defined by ASTM E2486.

**358.20 Ultra High Impact Mesh, 20 oz.**, ultra-high tensile strength glass fiber mesh.

*Uses:* Embedded in primary layer of basecoat prior to additional 355 Standard Mesh application to obtain ultra-high impact protection as defined by ASTM E2486.

## Primer

**Primer**, provides a color base over cementitious basecoat prior to finish application. It improves the color consistency, trowelability and coverage of the finish. May be tinted.

**Sanded Primer**, same as Primer, except it must be tinted to match and has a sand texture for improved application of the finish. Required (undiluted) for Cerastone, Spraystone, and Tuffstone Granite applications.

## Finishes

**Acrylic Finish:** 100% Acrylic co-polymer based, factory blended and integrally colored. They are applied over primed or unprimed basecoat to provide a durable, decorative wall coating.

**Cerastone, Spraystone, and Tuffstone Granite:** Colored aggregate in a clear binder. Sanded Primer must be used under these finishes.

**Elastomeric Finish:** 100% Acrylic-based elastomeric finishes. They are designed to go over new and existing stucco and concrete surfaces as well as either Stucco Level Coat or any EIFS Basecoat.

## Water-Resistive Barriers and Drainage Accessories

**StuccoWrap:** Secondary barrier material with engineered drainage channels, used with Mechanically Fastened EIFS (WaterMaster LCR)

**WeatherSeal Spray & Roll-On:** 100% acrylic based, spray & roll-on water-resistive barrier membrane. *Uses:* Secondary water and air-resistive barrier in the Commercial Drainage EIFS system.

**WeatherSeal Trowel-On:** 100% acrylic based, water-resistive barrier membrane. *Uses:* Secondary water and air-resistive barrier in the Commercial Drainage EIFS system.

**WeatherBlock:** A 100% Acrylic co-polymer fast drying vapor retarder, elastomeric waterproof and air barrier coating which can be either rolled, brushed, or spray applied.

*Uses:* Secondary water and air resistive barrier in the Commercial Drainage EIFS System

**396 Parex USA Sheathing Tape:** Non-woven synthetic fiber tape to reinforce Parex USA WeatherSeal Spray & Roll-On at sheathing board joints and rough openings. 500 ft. (152m) lengths in either 4 in. (10cm), 6 in. (15cm), or 9 in. (23cm) widths.

**365 Flashing Membrane:** Parex USA Flashing Membrane is a self-sealing polyester mat-faced, rubberized asphalt membrane that functions as a moisture and air barrier. It is 20 mils thick and grey in color. It can be applied to various substrates such as wood, metal, gypsum sheathing and to other water-resistive barriers. It functions as a seal and flashing at sills of rough openings, vented track and other similar conditions. It is available in two widths: 6 in. (152mm) and 12 in. (305mm) x 100 ft. (30.5m). Flashing Membrane Primer may be required for certain substrates.

**369 DrainEdge™:** A perforated, spun bonded, polyolefin used at heads of system penetrations (windows, doors, etc.) to permit drainage without the use of track on noncombustible construction.

## OTHER MATERIALS AND TOOLS YOU WILL NEED

**Insulation Board:** Ensure that the expanded polystyrene EPS insulation board used in the installation is listed for flame spread and smoke developed values, and conforms to ASTM C578 for Type I molded expanded polystyrene. Board should be aged a minimum of 6 weeks and be a maximum workable size of 2 ft. x 4 ft. (610mm x 119mm) with a minimum thickness of 1 in. (25.4mm) after rasping. To test the EPS board, break a small piece in half and immediately smell. The board should not be used if there is a noticeable solvent odor.

**Mechanical Fasteners:** Attachment method for mechanically fastened EIFS Systems. Mechanical fasteners are not required for the Parex USA Standard System. However, they are sometimes specified for added security. In some cases mechanical fasteners may be used for renovation work or where adhesive cannot be used.

**Vented Track:** Rigid exterior grade PVC plastic vented track designed to allow incidental moisture which may accumulate behind the system to exit. It may be used at foundation terminations in lieu of traditional backwrapping technique. Vented Track may not be used with Standard System or Commercial Drainage Systems except at foundation terminations, without approval from the Parex USA Technical Department.

**Portland Cement:** Use type I or I-II, fresh and free of lumps.

**Water:** Cool, clean potable water.

**Mixing Equipment:** Use a 1/2 in. (13mm) chuck size power drill with a 6-8 amp motor capable of turning at 400-500 rpm. The mixing paddle should be a steel dispersal mixer.

**Tools Common to the Plastering Trades.** Including, but not limited to: a hawk, scoop, stainless steel trowels, plastic floats, rasping boards, margin trowels, corner trowels, groove tools and notched trowels for adhesive application.

**Other Tools:** Utility knife, tape measure, paint rollers and tray (for primer), weight scale, extra buckets, electrical cords, EPS saw, drop cloths, masking tape, etc.

## PRODUCT STORAGE

- Generally, store all Parex USA products in a clean, dry environment, protected from sunlight. Protect all pail goods from freezing. Freezing can cause product damage. See product data sheets for specific storage instructions.
- Shelf Life: see product data sheets for specific shelf life information.
- Store EPS and tracks flat. Standing on end could cause these materials to warp.
- Store EPS away from sources of flame or high heat.  
**Warning:** EPS is combustible and can ignite and burn if exposed to fire of sufficient heat and intensity.
- Store Parex USA reinforcing mesh in the shipping container in order to keep it clean and protected.

## 2. GENERAL INSTALLATION REQUIREMENTS

*These requirements are essential to good exterior insulation finish system (EIFS) practice. Failure to follow these requirements could lead to problems with the installation or ultimately, to system failure. Follow the requirements of the Product Data Sheets for each Parex USA product used.*

### Environmental Requirements

- Parex USA products should only be used when the air temperature in which they are applied is at 40°F (4°C) or higher during application and drying/curing.
- Do not apply Parex USA products to substrates which have a surface temperature of 40°F (4°C) or lower.

**NOTE:** Because Parex USA Basecoats & Adhesives, Finishes and Coatings are water based acrylic products, it is essential that the above requirements be followed. Humidity, wind, cold, heat, rain, etc., can all affect workability and drying of the coatings. As conditions warrant, tenting and/or tarping with supplemental heat might be necessary to maintain these requirements.

The foam plastic insulation that is used in the Parex USA EIFS Systems is expanded polystyrene board, and the producers of the polystyrene boards recommend a maximum service temperature of 167°F (75°C). At temperatures higher than this value, the boards begin to deform. The use of dark color finishes over the polystyrene boards should be avoided in order to prevent the occurrence of high temperatures on the surface of the insulation boards. For more information see the Parex USA Technical Bulletin on using dark color finishes on EIFS.

### Substrate Requirements

Verify that the substrate:

- Is a type approved by Parex USA.
- Is sound showing no signs of deterioration.
- Is correctly applied and oriented to the framing.
- Is correctly and tightly fastened.
- Is free of any crumbling or looseness of surface.
- Has no gaps or voids other than what is necessary for proper installation.
- Has no projections or planar irregularities greater than 1/4 in. (6mm) in a 4 ft. (1.2m) radius.
- Is dry and is clean of any foreign materials such as oil, dust, dirt, form release agents, paints, wax, water, frost, etc.
- Wood-based sheathings require a 1/8 in. (3mm) gap between adjacent panels.
- Wood based sheathings require fastening in accordance with the building code or project specification if the specification exceeds the code.
- Gypsum sheathings require fastening spaced not more than 8 in. (20cm) on center along framing members, and framing spaced not more than 16 in. (40cm) on center. For greater framing spacing, contact Parex USA Technical Services. Closer fastener spacing may be required by project specification or code.

### Application Coordination Requirements

- Ensure that the installation of the system is being coordinated with other trades on the project.
- Other trades are responsible for metal or plastic flashings as detailed by the design professional and must be installed properly along with other construction components such as windows and doors, louvers, doors, roof intersections, and deck headers.
- Make sure details needed prior to application of EIFS are acceptable and in place.
- Provide appropriate protection/covering for adjacent construction materials that are likely to be soiled by the application process.
- Employ sufficient manpower to ensure a continuous coating application free of cold joints, scaffold staging shadows and texture variations.
- Have scaffolding and other necessary equipment in place prior to the installation.
- Have access to electricity for power tools.
- Have access to cool, clean water of drinking quality at the area where system materials will be mixed.
- Determine who will be responsible for installing the sealant.

### Before Beginning the Installation

If there are any discrepancies with your initial inspection of the substrate, do not proceed with the application until all unsatisfactory conditions are corrected. The general contractor should be advised of all discrepancies so that appropriate action can be taken. Failure to advise the general contractor of unsatisfactory conditions before the application begins might be construed as acceptance, by the applicator, of the substrate for the purpose of installing the system. At this time, it may also be appropriate to once again review the contract documents to ensure that the installation will be consistent with what has been detailed and specified. Be sure to review critical detail areas of the project. It is certainly easier for all parties concerned if problems are addressed "up front" rather than when they present themselves in the installation process.

Evaluate the installation - The following are some critical details:

1. Window and door perimeters
2. Tops of walls (roof line)
3. Bottom of walls (grade or pavement)
4. Penetrations (scuppers, fixtures, outlets, signage, etc.)
5. Aesthetic features
6. Expansion joints
7. Abutments to Dissimilar Materials
8. Gable Roof/Wall Intersection
9. Flashing Locations
10. Roofing
11. Kick-out Flashing (flashing turn-outs)



### 3. APPLICATION OF THE STANDARD SYSTEM

The system should start 6 in. (15cm) above grade or 2 in. (5cm) above the pavement. Substrates allowed are masonry, brick, stucco, exterior gypsum sheathing, glass mat gypsum, cement board, plywood and OSB sheathing. **The system is qualified for application to certain types of OSB (oriented strand board) sheathing only in areas shown in the Parex USA Acceptable Substrates and Areas of Use Technical Bulletin.**

#### Backwrapping

Backwrapping is the traditional method of encapsulating the insulation board edge. Backwrapping simply means that the insulation board edge is completely wrapped in mesh reinforced basecoat, and that the mesh continues in back of the insulation board edge.

First determine the starting point on the wall. Then snap a straight, level chalk line. To begin backwrapping, install Parex USA 9-1/4 in. (23.5cm) wide 356 Detail Mesh lengthwise along chalk line so that a minimum of 2-1/2 in. (6.5cm) of the mesh will be behind the insulation board. The detail mesh can be installed by either using Parex USA Adhesives, or by attaching the mesh onto sheathing substrates with corrosion resistant staples or nails in a length that does not penetrate through the sheathing.

If Parex USA Adhesive is used to attach the mesh to the substrate, special care should be taken to ensure that the exposed ends of the backwrapping mesh do not become covered with adhesive materials. (Fig 4.1) Adhesive on the exposed ends will prevent proper embedding of the mesh at the board edge and face when the backwrapping procedure is completed later.

Track is used at foundation terminations as an alternative to backwrapping and other locations on combustible construction only. Although it cannot be used in every situation, it provides a factory formed termination. Track also provides an excellent substrate for sealant bonding. Track may not be used on Standard Systems or Commercial Drainage Systems except at foundation terminations. For special exceptions, contact the Parex USA Technical Department.

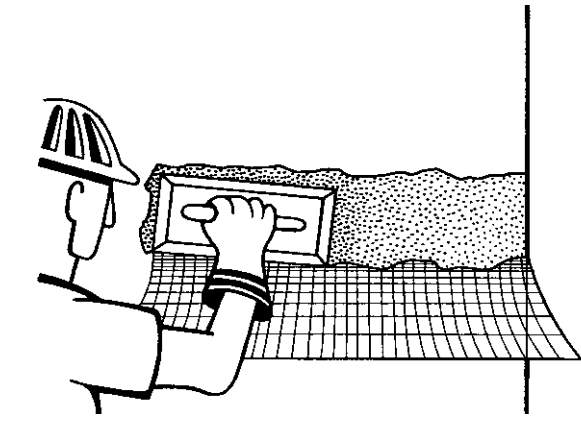

Fig 4.1

## INSTALLING THE INSULATION BOARD

### Choosing the Right Adhesive

After the preliminary task of backwrapping or fastening track has been accomplished, you are now ready to adhere the EPS insulation board to the substrate. The adhesive should be selected depending upon the substrate. Table 5.1 below is a guide for matching adhesives with substrates.

**Table 5.1: ATTACHMENT BY SUBSTRATE**

	<b>SUBSTRATES</b>	<b>ADHESIVE</b>
Masonry Type Substrates (unpainted)	CMU	any Cementitious Adhesive
	Poured in place & Pre-Cast Concrete	any Cementitious Adhesive
	Brick	any Cementitious Adhesive
Sheathed Substrates (unpainted)	Exterior Gypsum Sheathing	any Cementitious Adhesive, 100% Acrylic, Sheathing Adhesive
	Glass Mat Gypsum Sheathing	any Cementitious, 100% Acrylic, Sheathing Adhesive
	Cement Board	any Cementitious Adhesive
	Metal Siding	100% Acrylic Basecoat & Adhesive, Sheathing Adhesive and M.F.**
	Wood Sheathing	100% Acrylic Basecoat & Adhesive, Sheathing Adhesive
Substrates coated with Parex USA WeatherSeal or WeatherBlock	Exterior Gypsum Sheathing, Glass Mat Gypsum Sheathing, Cement Board, Wood Sheathing, Masonry, Brick	Any Adhesive
Expanded Metal Lath	Nominal 3.4 lb./sq. yd., flat, galvanized G 60 or greater	any Cementitious Adhesive

\*\*M.F. Mechanical Fasteners - please contact Parex USA Technical Services.

### Starting and Stopping the System

At all system terminations, install 356 Detail Mesh for back-wrapping. When using 356 Detail Mesh, be sure to backwrap the mesh at least 2-1/2 in. (6cm) behind insulation board.

### Applying EPS Insulation Board to Sheathing Substrates

On sheathing applications, the first course of insulation board usually must be halved in width to allow for a minimum 1 in. transition beyond the sill plate and the 12 in. (30cm) offset of the horizontal insulation and sheathing board joints (Fig 5.1). The offset of the vertical insulation and sheathing board joints typically should be no less than 8 in. (20cm). **Remember**, at no time should the vertical or horizontal joints in the sheathing line up with the insulation board joints. On masonry substrates these requirements do not apply.

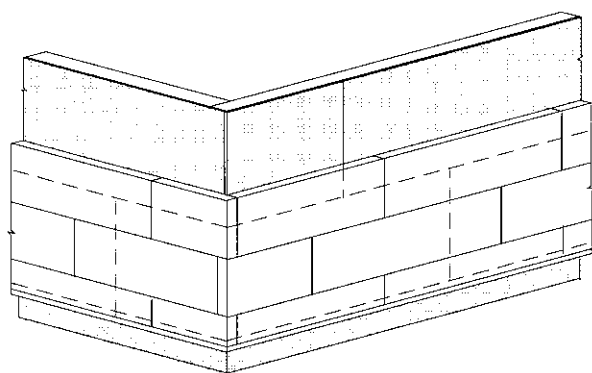

Fig 5.1

## Applying EPS Insulation to Masonry Substrates

EPS board must not bridge expansion joints in masonry or concrete substrates. Instead, an expansion sealant joint is created in the EIF System over the substrate joints.

## Adhesive Application Trowels

Sheathing Adhesive requires that these trowels be used with these products for optimum adhesive performance and coverages:

### Trowel Size:

5/8 in. (16mm) U-notched trowel for masonry, concrete and metal lath substrates with any Cementitious Basecoat & Adhesive (Fig 5.2).

1/2 in. (12mm) U-notched trowel for sheathing substrates with any Cementitious Basecoat & Adhesive (Fig 5.3).

3/16 in. (5mm) U-notched trowel for sheathing substrates with Sheathing Adhesive (Fig 5.4).

5/16 in. (8mm) U-notched trowel for sheathing substrates (Fig 5.5).

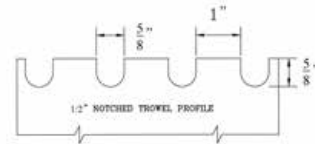

Fig 5.2

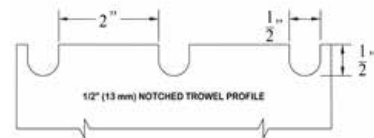

Fig 5.3

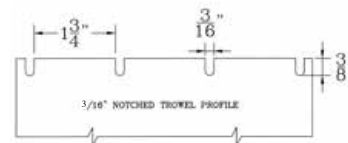

Fig 5.4

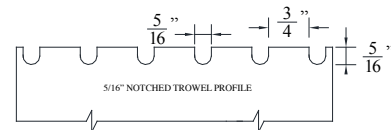

Fig 5.5

## Applying Adhesive to the Back of the EPS Insulation Board

The first step is to ensure that the adhesive is compatible with the substrate. Using the correct sized notched trowel, the adhesive can now be applied to the insulation board.

Apply the adhesive to the back-facing side of the insulation board so that when it is applied to the substrate, the notched trowel pattern runs consistently (Fig 5.6).

The notched pattern should cover the entire board from edge to edge. To ensure sufficient bonding and coverages of the adhesive, EPS board should be visible in between the notches of adhesive. Adhesive should only be applied to the back-facing side of the insulation board. Remove any adhesive from EPS board edges. Adhesive between board edges can cause cracking.

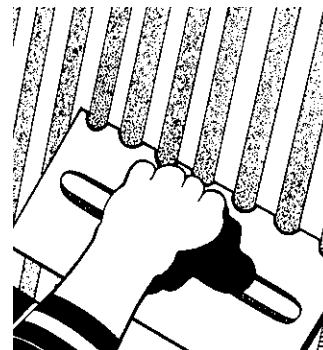

Fig 5.6

## Installing the Insulation Board

Prior to installing the insulation board it is important to assess all terminations of the system and ensure that backwrapping, edge wrapping, track or seal tape is used in these locations.

Slide and push the insulation boards into place on the wall using caution not to dent or damage the board. Insert insulation board (Fig 5.7) edges all the way into track or backwrap. Apply firm, even pressure to the entire insulation board once it is in place. A rasping board is a useful tool to press with even pressure without damaging the insulation board. Install the insulation board in a running bond pattern, staggering vertical joints in successive courses. Best practice would be no less than 8 in. (20cm) from the adjacent insulation board joints.



Fig 5.7

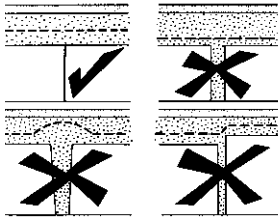

Fig 5.8

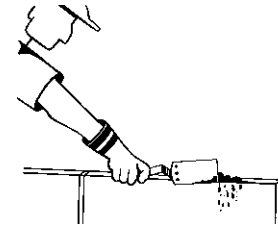

Fig 5.9

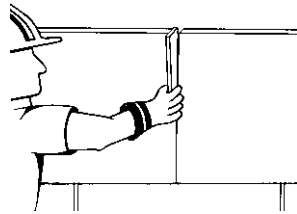

Fig 5.10

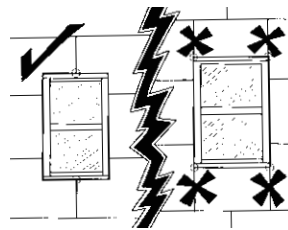

Fig 5.11

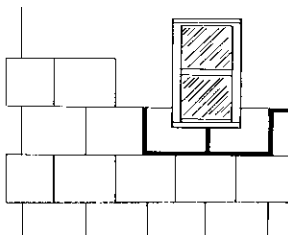

Fig 5.12

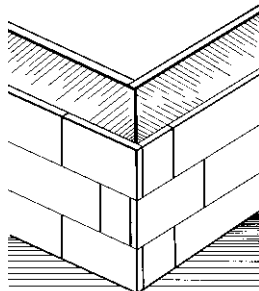

Fig 5.13

Abut boards tightly at joints to produce a flush, continuously even surface with minimum gaps (Fig 5.8). Scrape excess adhesive off the edges of the boards (Fig 5.9).

Fill any gaps larger than 3/32 in. (2mm) with slivers of insulation board (Fig 5.10) or a Low Expanding Polyurethane Spray Foam approved for use with EIFS. Adhesive should not be applied to the slivers. Continue installing the EPS boards horizontally, staggering the boards and overlapping the substrate joints. Filling gaps with adhesive/basecoat will result in cracks in the lamina.

Offset insulation board joints 8 in. (20cm) or more from the corners of openings around doors, windows or other similar conditions (Fig 5.11). Plan the work so that the insulation board around the corner is cut in an "L" shape from a single piece (Fig 5.12). Insulation board joints should never align with opening corners.

Leave a uniform 1/2 in. space between the edge of the EPS and the window, door, etc. when the system is terminated by backwrapping, so that backer rod and sealant can be installed later.

At all outside and inside corners always interlock or stagger the insulation board joints, board joints on the opposite end should be no less than 8 in. (20cm) from the corner (Fig 5.13). Plumb all outside corners by snapping a chalk line. Level the EPS board to the chalk line by rasping. Maintain a minimum thickness of 3/4 in. (19mm) of EPS. Remove all loose EPS particles from the wall surface.

## PREPARING FOR THE BASECOAT APPLICATION

The adhesive must dry so that EPS board is secure on the wall before proceeding. Adhesive must dry in accordance with the product data sheet. Drying time may be shortened with Parex USA Accel-Pak. In cool or damp weather, the adhesive may require longer to drying time.

### Leveling the EPS

True wall surfaces by leveling EPS. Do not build up basecoat thickness to true walls. Level the entire surface of the EPS board with either a rasping board or power rasper (Fig 6.1).



Fig 6.1

Check the surface with a straight edge for high spots, leveling as necessary (Fig 6.2). Maintain a minimum thickness of 3/4 in. (19mm) of EPS. Thoroughly remove loose EPS particles from the surface of the insulation board.

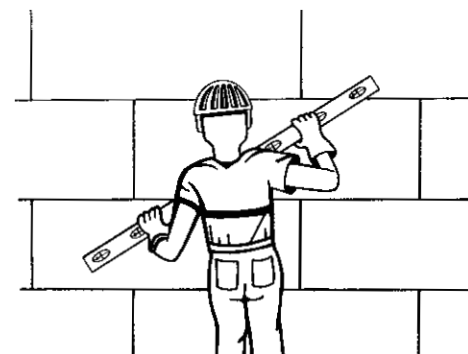

Fig 6.2

### Aesthetic Grooves or Reveals

Establish the locations of all aesthetic grooves or reveals, bands or other projections with a chalk line. The aesthetic grooves should not line up with the EPS board joints.

Aesthetic grooves or reveals can generally be cut with a router or hot knife. A minimum thickness of 3/4 in. (19mm) of insulation board must be maintained in back of the groove (Fig 6.3). The bottom surface of any horizontal groove must be sloped min. 1 in 2 pitch.

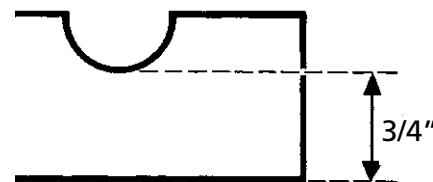

Fig 6.3

### Attaching EPS Aesthetic Trim

The following Parex USA adhesives can be used to attach foam to foam: any Cementitious Basecoat & Adhesive.

Small EPS aesthetic trim not more than 3 in. (7.6cm) thick by 12 in. (30cm) wide can now be laminated over installed insulation board (Fig 6.4), not exceeding the grand total thickness as allowed by the system specifier. Using either a 5/16 in. (8mm) or 1/2 in. (13mm) notched trowel, apply Parex USA Adhesive to the back of the trim feature, as described earlier. Attach the trim piece to the face of the insulation board with firm and even pressure. In some cases it may be necessary to temporarily pin the trim into place with nails to give the adhesive time to set up. Remove temporary pinning after the adhesive has dried.

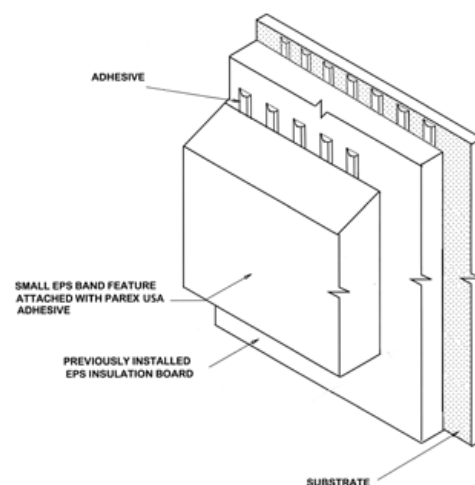

Fig 6.4

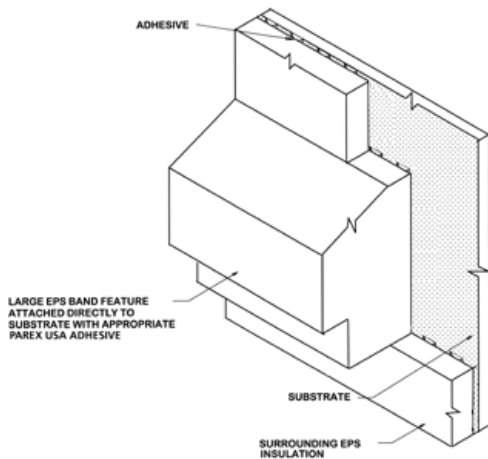

Fig 6.5

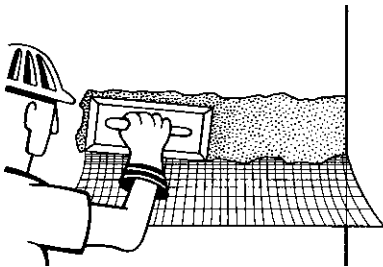

Fig 6.6

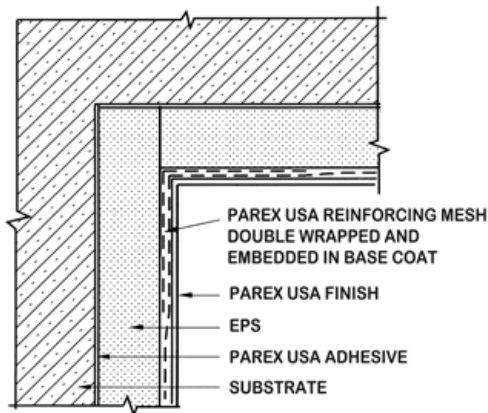

Fig 6.7

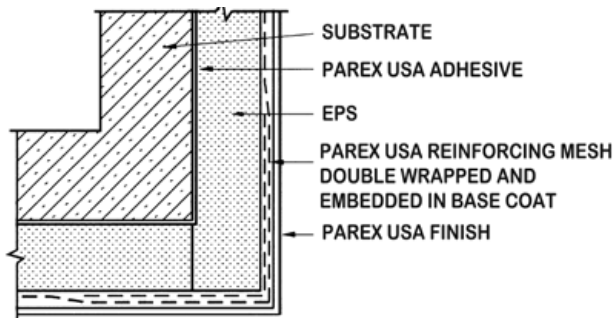

Fig 6.8

Larger EPS aesthetic trim should be attached directly to the substrate (Fig 6.5). Using the appropriate notched trowel for the adhesive specified, apply adhesive to the back-face of the trim feature as described earlier. Attach the trim piece directly to the substrate with firm and even pressure. If necessary, corrosion-resistant mechanical fasteners may be used in conjunction with the appropriate Parex USA Adhesive to affix the feature temporarily or permanently (Please contact Parex USA Technical Services for recommendations). Allow the adhesive to fully dry a minimum of 24 hours, or longer depending on conditions, before rasping and basecoating aesthetic trim features.

### Backwrapping Mesh

Check that EPS has all been leveled before proceeding. At this time, all terminations to be backwrapped should have free-hanging detail mesh in place (Fig 6.6). To continue the backwrapping procedure, trowel the specified basecoat onto the exposed insulation board edge and face in an area wide enough to embed the width of backwrapped mesh. Embed the mesh into the fresh basecoat with a stainless steel trowel. Corner trowels should be used to properly embed the returns.

### Meshing Corners

The inside corners should be double-wrapped with reinforcing mesh. This can be done using one of two different methods:

(1) Apply a primary layer of basecoat wide enough to accommodate Parex USA 356 Short Detail Mesh. Embed the mesh into the fresh basecoat, then apply the 355 Standard Mesh around the corner so there is a double layer of mesh (Fig 6.7).

(2) Another way to double mesh corners is to wrap and embed mesh in basecoat around the corner from one side to the other side. Next duplicate this process coming from the other side. The double mesh should extend at least 8 in. (20cm) from the corner in both directions. (Fig 6.8).

Outside corners can be meshed in a similar manner. For greater strength and a sharper line, use Parex USA 357 Corner Reinforcing Mesh. This heavy duty reinforcing mesh is easily folded for ease of application. Standard mesh is then lapped over the corner mesh and extends at least 8 in. (20cm) from the building corner.

A corner trowel should be used to smooth out the corner at its edge, forming a clean, straight line. If necessary, apply additional basecoat materials to ensure that the mesh is not visible. A slight pattern of the mesh is acceptable, due to shrinkage of the cementitious basecoat upon drying.

## Meshing Aesthetic Grooves or Reveals

The mesh-reinforced basecoat must be continuous through these recessed features. To mesh the groove or reveal, apply a primary layer of basecoat into the groove and over an area wide enough to embed the width of the detail mesh on either side (Fig 6.9).

Begin embedding the Parex USA 356 Detail Mesh into the groove using a tool fabricated in the profile of the feature (Fig 6.10). Do not cut the mesh during this process.

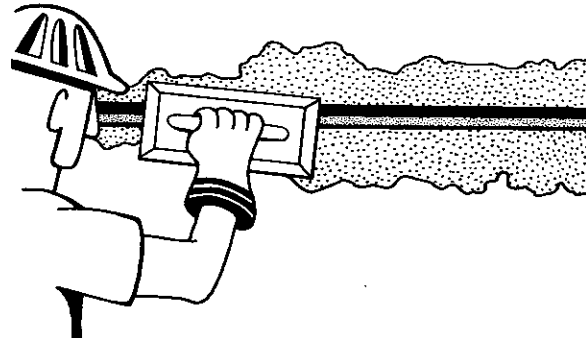

Fig 6.9

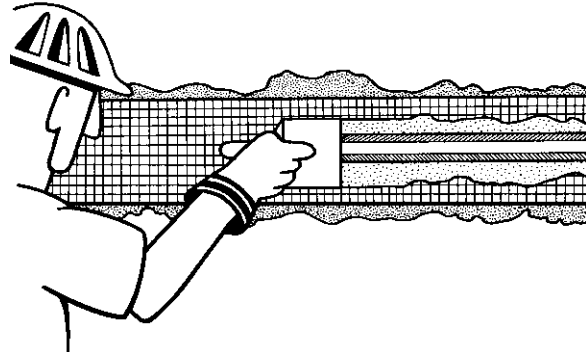

Fig 6.10

With a trowel, finish embedding the detail mesh on the sides of the groove (Fig 6.11). If the mesh is still visible, apply additional basecoat. A slight pattern of the mesh is acceptable, due to shrinkage of the cementitious basecoat upon drying.

## Meshing Aesthetic Trim

As a general rule, adhesives used in attaching aesthetic trim should be allowed to dry a minimum of 24 hours or longer, depending on conditions, before applying basecoat.

Aesthetic trim features are prepared with a basecoat similar to the rest of the wall system. Basecoat and embedded mesh should not only be applied to the feature, but should also lap not less than 2-1/2 in. (6.5cm) onto the adjacent wall plane. Completely embed mesh in the fresh basecoat. Apply additional basecoat as necessary to completely cover the mesh.

Like aesthetic grooves and reveals, the area adjacent to the feature is overlapped with mesh reinforced basecoat during the standard application procedure.

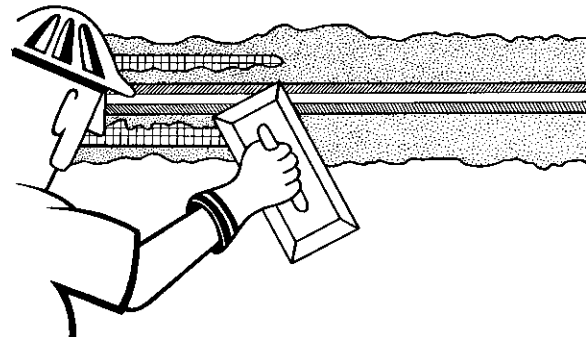

Fig 6.11

## Butterfly Reinforcements

Apply "butterfly" corner reinforcing mesh diagonally at the corners of all openings such as doors, windows, recessed features, etc. Butterfly mesh is cut from 356 Detail Mesh to a length of 12 in. (30cm). Apply butterfly mesh at corners of bands around openings (Fig 6.12). The dimensions of the butterfly mesh may be reduced to fit the bands. The continuous wall mesh is applied either under or over butterfly mesh.

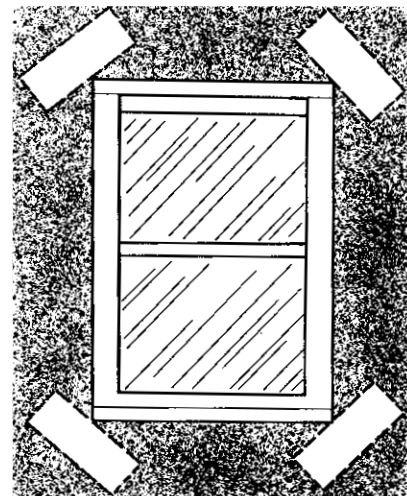

Fig 6.12



Fig 7.1

## APPLYING BASECOATS

To begin this step, cut reinforcing mesh to workable lengths.

### Standard Mesh and Basecoat Application Procedure

All Parex USA Basecoats are applied to the face of the insulation board in the same manner. Using a stainless steel trowel, apply an even layer of basecoat approximately 1/16 in. to 3/32 in. (1.6mm to 2mm) thick onto the surface of the insulation board in an area slightly larger than the 38 in. (1m) width of the reinforcing mesh.

Immediately embed the reinforcing mesh into the fresh basecoat, trowelling it from the center and outward to its edges, cutting off any accumulated excess basecoat (Fig 7.1).

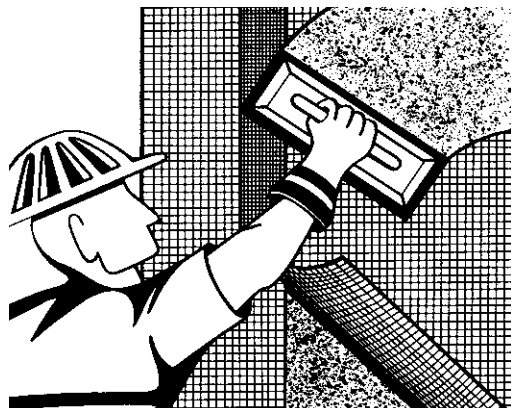

Fig 7.2

This method keeps the mesh laying flat, ensuring consistent embedment into the basecoat. In the event that any portion of the embedded mesh is still visible, apply a second skim coat (Fig 7.2).

The installation progresses by applying basecoat similarly in areas adjacent to the previous application. Take care to overlap reinforcing mesh a minimum of 2-1/2 in. (6.5cm) at all meeting ends and edges as the application progresses. To avoid a buildup of basecoat that could be noticeable in the finished application, mesh end overlaps can be held 8 in. (20cm) or more from corners.

After drying the color of the reinforcing mesh should not be visible at the surface of the Basecoat & Adhesive material. A slight pattern of the mesh is acceptable, due to shrinkage of the cementitious basecoat upon drying.

### Final Appearance of Basecoat Application

The basecoat application should be smooth, approximately 1/16 in. (1.6mm) thick, and free of trowel lines with no visible color signs of the reinforcing mesh. Allow a minimum drying time of 24 hours (or in accordance with Product Data Sheet) or longer depending on conditions, before applying additional Parex USA coatings. Drying time may be shortened with Parex USA Accel-Pak. This allows the basecoat to form a positive bond.



## IMPACT MESH APPLICATION

In areas requiring heavy duty impact protection, Parex USA offers two options: 358.20 Ultra High Impact Mesh, which is 20 oz. mesh, and 358.14 High Impact Mesh which is 15 oz. mesh. Requirements are generally outlined in the job's specification and are shown on the drawings.

At areas specified for impact protection, apply Parex USA basecoat approximately 3/32 in. (2mm) thick to the insulation board. Immediately embed Parex USA heavy duty mesh into the wet basecoat.

Edges and ends of heavy duty mesh must tightly abut one another. **Do not overlap heavy duty mesh.**

Either allow the basecoat embedding the heavy duty mesh to dry completely or immediately embed standard mesh over it. Unless standard mesh is immediately applied, cover heavy duty mesh completely with basecoat, allow a minimum of 24 hours to pass, or longer depending on conditions, prior to applying additional Parex USA coatings. This allows the first layer of basecoat to form a positive bond.

Examine the hardened first layer of basecoat for projections of loose strands of reinforcing mesh. Correct as necessary to produce a flat working surface.

The next step is to apply a second layer of basecoat and to embed Parex USA 355 Standard Mesh.

The 355 Standard Mesh joints must be offset a minimum of 6 in. (15cm) from the joints of the previously installed heavy duty mesh. Standard and heavy duty mesh ends and edges should never align.

## Intermediate Impact Resistance

For intermediate impact resistance, Parex USA 358.10 Intermediate Impact Mesh is applied in the same manner as high impact applications, followed by an application of 355 Standard Mesh embedded in basecoat.

As an alternative, when specified, Parex USA 358.10 Intermediate Impact Mesh can be embedded into wet basecoat with edges and ends tightly abutted. Immediately following this procedure, Parex USA 356 Short Detail Mesh strips are centered over the butted ends and edges of the 358.10 Intermediate Reinforcing Mesh. Additional basecoat is applied to feather out the mesh joints and to completely embed the mesh to produce a flat, uniform surface.

Intermediate mesh may also be overlapped a minimum of 2-1/2 inches, however care must be taken to avoid a bump in the basecoat at this termination and the basecoat must be feathered onto either side.



Fig 9.1

- The Parex USA Sand Smooth Finish cannot generally be floated. Texture will be “as-trowelled”. For the smoothest application, apply in two tight coats. Allow first coat to dry enough that it will not be disturbed during application of the second coat. When second coat is partially dry, trowel to desired smoothness. Light, consistent misting with water during smoothing will increase smoothness. Variations in color tint and smoothness should be expected.

## FINISH APPLICATION

Before the application of the finish, the basecoat must be dry and have cured a minimum of 24 hours or longer as required by conditions or in accordance with the product data sheet. Examine the cured basecoat for any irregularities. Correct these irregularities to produce a flat surface. Review environmental and application coordination sections of the General Requirements. Work on the shaded side of the building whenever possible.

### Primer or Sanded Primer

Primer is optional, except if specified, when applying finishes to cementitious basecoats. Primer is applied to minimize cementitious basecoat water absorption and the risk of efflorescence, and to provide consistent color under the finish. It also eases the trowelability floating characteristics of the finish, and will improve the coverage of the finish.

- Parex USA Variance VariPrime Sanded is required for Cerastone, Spraystone and Tuffstone Granite Finishes.

### Mixing and Applying Primer

Mix the primer thoroughly with the appropriate mixer and adjust consistency with up to 2 gal (3.8 L) of cool, clean potable water for ease of application. Apply the primer by either rolling or spraying with suitable equipment in a continuous coat (Figs 9.1). The primer does not have to look like a professional paint job, but it should cover the basecoat. When cutting-in with a brush around edges of the system do not allow a buildup of primer. If a buildup is present it will produce a visible and unsightly difference in the finish applied over it.

Cerastone, Spraystone and Tuffstone Granite finishes:

Sanded Primer is required and must be uniform, with no variation in appearance from basecoat showing through. Sanded Primer must be specifically tinted for Cerastone, Spraystone and Tuffstone Granite colors.

### Parex USA Finishes

Parex USA offers a variety of different finishes in a wide range of colors that can accommodate a variety of texturing techniques. Each finish is acrylic polymer based, pre-mixed, and tinted for the requirements of any project.

- Swirl Finishes are applied with a stainless steel trowel and textured with a hard plastic float.
- Parex USA Variable Texture Finish is a high-build product that can be applied using various application techniques.
- Parex USA Sand Finishes are applied using a stainless steel trowel and textured with a stainless steel trowel or a plastic float.
- The Sand Fine Finish is less forgiving on irregular substrates. Use extra care on the basecoat to control consistency of the texture.
- Using the appropriate spray equipment and techniques, all Parex USA acrylic finishes can be sprayed to achieve a wide variety of textures.

## Mixing Parex USA Acrylic Finishes

Stir to obtain a homogenous consistency using a heavy duty 1/2 in. (13mm) drill with a rust free mixer at 400-500 RPM (Fig 9.2). Avoid air entrapment.

To adjust workability, small amounts of cool, clean, potable water may be added as necessary. Do not exceed the amount of water recommended on the product data sheet. If water is added be sure that the same amount is added to each subsequent pail used. This ensures color and texture consistency.

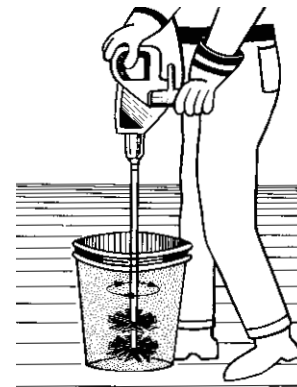

Fig 9.2

Use single batch numbers of finish within a wall area defined by corners. Batch numbers are marked on the pail. If changing batches within a wall is unavoidable, then intermix batches to ensure consistent product. (Fig 9.3).



Fig 9.3

## Assessing the Finish Application

In assessing the finish application, keep in mind that the material must be applied continuously for best results. When possible, plan the day's work to best take advantage of terminations in the wall plane. For example: work between columns, aesthetic joints, expansion joints, corners, etc. For larger areas sufficient manpower must be assembled to ensure an application free of cold joints and staging lines (Fig 9.4).

Direct sunlight, wind, temperature and humidity can all have an effect on the workability and drying time of Parex USA finishes. When possible, work the shady side of the building or tarp the scaffolding.

## Fundamentals of Successfully Applying Finish

- Get samples approved and signed by the customer before the finish is made.
- Box finish from different batches.
- Run one batch of finish from corner to corner.
- Avoid application in direct sunlight.
- Always work to a wet edge.
- Have sufficient manpower to work a job.
- Stop work at a termination point.

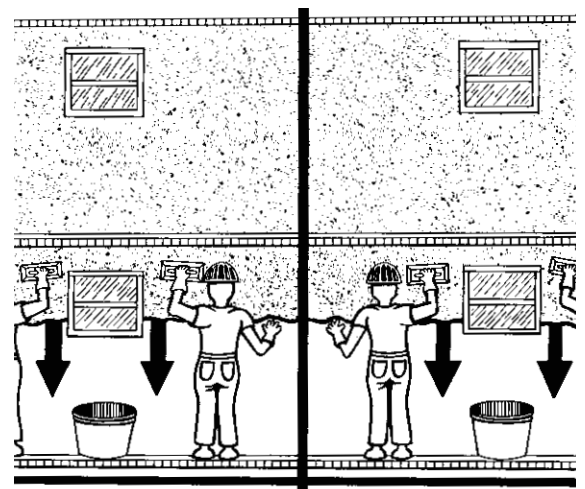

Fig 9.4

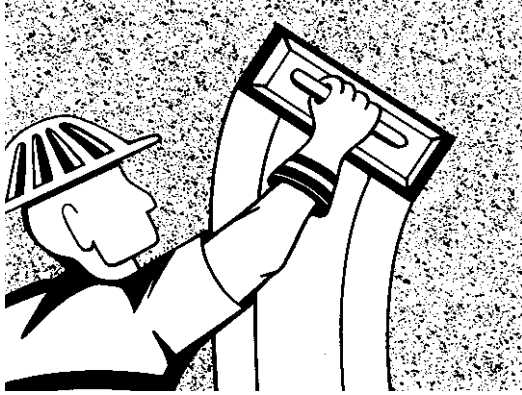

Fig 9.5

## Applying Parex USA Finishes

Use the same tools and techniques to apply and texture the finish as used for the approved samples.

Apply Parex USA finishes with a clean stainless steel trowel (Fig 9.5). The thickness of the finish application should equal the size of the product's aggregate. Variable Texture Finish can be applied up to 1/4 in. (6mm) thick at thickest part of a texture pattern, but its average thickness is limited to 1/8 in. (3mm) maximum.

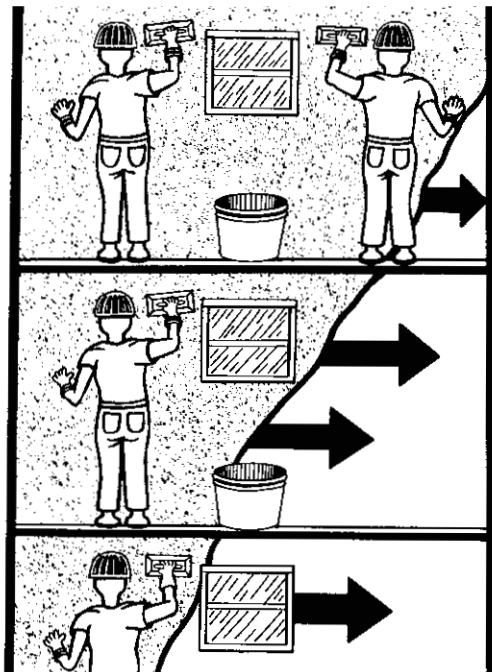

Fig 9.6

## Do not apply finishes on or in areas to receive sealant.

To ensure that the application remains consistent, a "wet edge" must be maintained at all times between termination breaks in the wall area (Fig 9.6).

## Texturing Finish

Parex USA Swirl Finishes can be textured using a hard plastic float in a uniform circular or figure eight motion (Fig 9.7). To ensure consistency in the application, all applicators should use the same type of tool and motion to float.

During texturing, frequently remove any buildup of finish on the plastic float. For best results, two passes with the plastic float are recommended. **Warning:** Do not allow water on the float or wall while texturing. The additional water from the float may result in a visible color difference when the finish application has dried.

Parex USA Variable Texture Finish can be applied and textured much like other plaster type materials. Using traditional plastering methods use Variable Texture to create skip trowel or stipple effects. **Remember:** Variable Finish should not exceed 1/4 in. (6mm) at its thickest point and should average no more than 1/8 in. (3mm) thick.

Parex USA Sand Finishes are used to achieve a relatively uniform texture. Apply, then texture these finishes with a stainless steel trowel or hard plastic float using the same guidelines mentioned for Swirl Finishes. See the Product Data Sheet for more information.

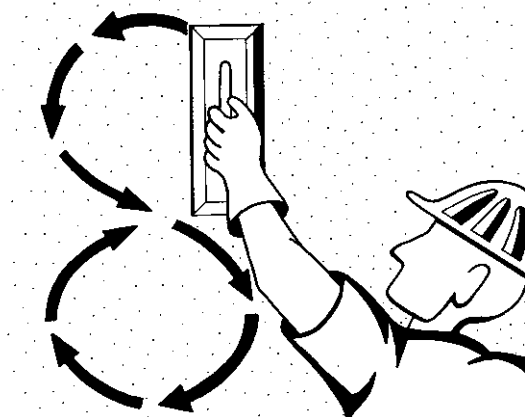

Fig 9.7

## **PROTECTING THE SYSTEM AFTER INSTALLATION**

- Plan and have ready for immediate use any protective measures required.
- Immediately after installation protect the Parex USA System from weather and other damage until all sealants and flashings have been installed.
- After each application of the basecoat & adhesives and finishes, the ambient air temperature must remain at 40°F (4°C) or higher for a minimum of 24 hours, or until the coatings are completely dry, which may take several days in high humidity and/or cool weather.

Although it may not be outwardly apparent, freshly applied coatings that seem hard and dry on the surface often require protective measures to ensure their proper cure through their entire thickness. Take protective measures, especially if freezing temperatures, rain, snow or other damaging weather conditions are likely.

Temperatures below 40°F (4°C) can slow down or stop the film formation of the acrylic polymers. Damage from cold conditions often remains undetectable in the short term, but shows up much later as the coatings crack, become crumbly, or delaminate.

Like excessive cold, precipitation can affect the proper curing of coatings, but its results can be dramatically fast. A sudden downpour can wash fresh uncured coatings directly off a wall.

As circumstances may dictate, work according to the weather or provide appropriate sheltering, such as tenting and/or tarping. To maintain proper curing temperature, supplemental means of heating the temporary shelter may have to be used.

### **Flashings and Sealants**

EIF systems, like other weather-protective wall materials, rely on flashings and sealants to prevent moisture entry behind the materials. Moisture behind the system can lead to damage to the interior of the wall. On moisture sensitive substrates, moisture can cause delamination of the system or loss of substrate attachment.

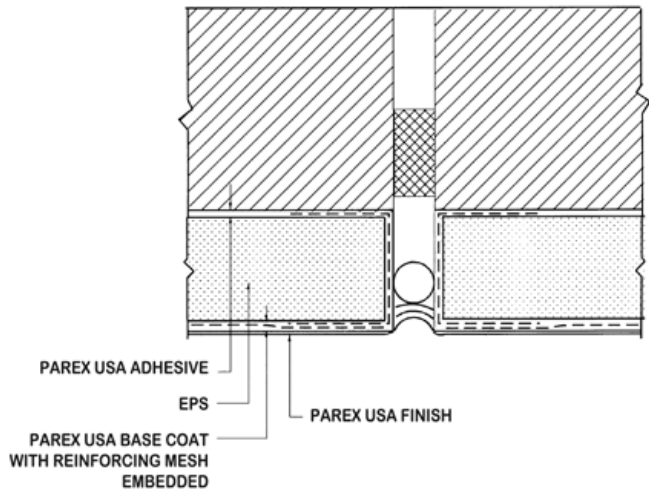

Fig 10.1

## More About Sealants

Sealants, provide two vital functions:

1. They effectively seal joints between abutting materials against the weather; and
2. They absorb thermal expansion and contraction. In general, sealant joints are constructed similar to Fig 10.1. Parex USA requires the surface of the system which will receive the sealant to be either mesh-reinforced basecoat or track. Do not return finish into the joints or other areas to receive sealant. Sealants are applied in strict conformance with the sealant manufacturer's recommendation.

Because of the wide variety of surface materials and conditions, check with the sealant manufacturer to ensure compatibility of the sealants to the surface(s) to which they will be applied. Special surface preparation or primers may be necessary. **NOTE: Parex USA Basecoats and Finishes must be thoroughly dry before sealants can be applied. Parex USA Cementitious Basecoats require a minimum drying time of three days and longer during conditions of cool temperatures or high humidity; Parex USA 100% Acrylic Basecoat and Finishes may require further drying time.**

## 4. STEPS FOR MECHANICALLY FASTENED EIFS FOR LIGHT COMMERCIAL AND RESIDENTIAL CONSTRUCTION

**NOTE:** All WaterMaster LCR systems require waterproofing of all openings prior to system application and 1-1/2 in. (38mm) minimum EPS thickness.

### INSTALLING VENTED TRACK

Vented track provides a means for incidental moisture to escape at the bottom of the system. Install vented track along a level or plumb base line approximately 6 in. (152mm) above grade or 2 in. (51mm) above pavement. Install above flashings and at expansion joints. Attach the track to the substrate at 10-12 in. (254-305mm) intervals along its length and insert splices at all track joints. On **Mechanically Fastened EIFS** installation of the **Water-Resistive Barrier must lap into the track.**

On sheathing substrates, fasten the track through the sheathing and into the framing. Use corrosion resistant screws, nails or masonry anchors as appropriate for the substrate. Bottom of vented track shall be not less than 1 in. (25mm) below bottom of wall framing (Fig 11.1).

At this point in the construction, sheathing must be on the building. **WINDOWS AND DOORS MUST NOT BE IN PLACE.** Vented track should be installed at the bottom termination point.

The next step is to properly wrap all rough openings with Parex USA Flashing Membrane or StuccoWrap™ FlexWrap™ or Reinforced Parex USA WeatherSeal. Closely follow the instructions below:

Parex USA recommends an adhesion test of the Flashing Membrane on the substrates. If adhesion to substrate is found to be marginal, a primer shall be used to ensure optimal adhesion. Metal surfaces may need to be solvent wiped or abraded to achieve good adhesion. The recommended primers used with 365 Flashing Membrane are the Protecto Wrap No. 6000 Water-Based Primer or the Protecto-Tak Spray Adhesive.

- 1. Installing the Corrugated Water-Resistive Barrier Under the Sill:** Cut to 12 in. (305mm) and approximately 2 in. (610mm) wider than window and staple into place at the bottom of the rough opening (Fig 11.2).
- 2. Installing Membrane "Bandages":** Cut "bandages" to 4 in. (102mm) x 6 in. (152mm). Peel protective backer from the membrane and install diagonally at sill corners as shown. Sheathing or Corrugated Water-Resistive Barrier should not be visible at the corners of the rough opening (Fig 11.3). This step can be skipped if a "T" strip of Parex USA 365 Flashing Membrane is applied in the corner and over the Corrugated Water-Resistive Barrier.
- 3. Cutting Flashing Membrane:** Cut a piece of 365 Flashing Membrane 8 in. (203mm) longer than the rough opening width. Make two small cuts 2 in. (51mm) long through the membrane.
- 4. Folding Flashing Membrane:** Fold membrane to conform with rough opening. Peel protective backer from membrane to expose adhesive (Fig 11.5).
- 5. Installing the Flashing Membrane:** Install the "self sticking" membrane at the rough opening. Membrane should lap over the previously installed "bandages" and Corrugated Water-Resistive Barrier (Fig 11.6).



Fig. 11.1

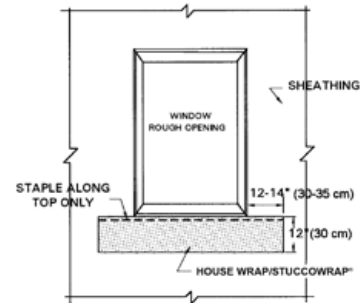

Fig. 11.2

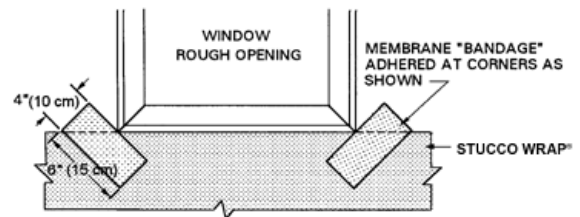

Fig. 11.3

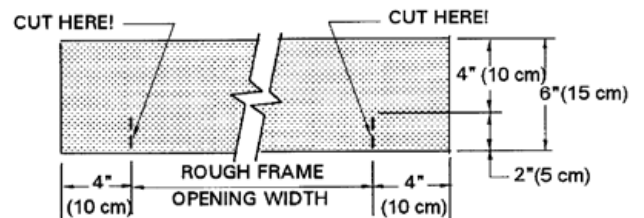

Fig. 11.4

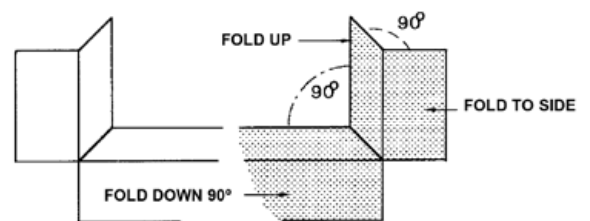

Fig. 11.5

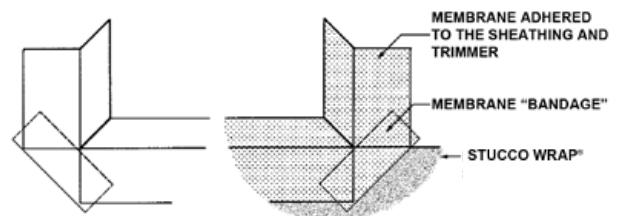

Fig. 11.6

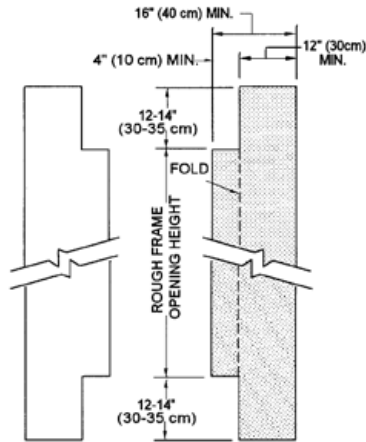

Fig. 11.7

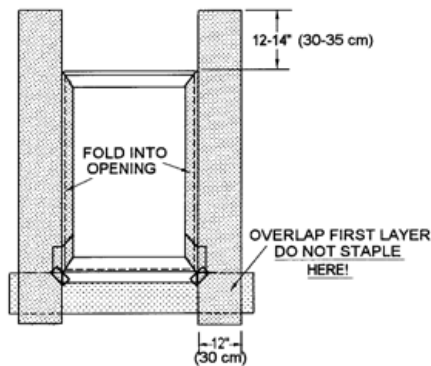

Fig. 11.8

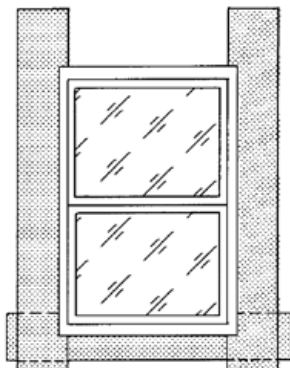

Fig. 11.9

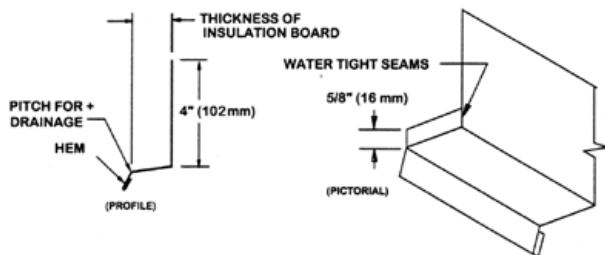

Fig. 11.10

6. **Cutting Water-Resistive Barrier for Jambs:** Cut Water-Resistive Barrier to fit rough opening jamb (Fig 11.7).

7. **Installing Water-Resistive Barrier at Jambs:** Fold Water-Resistive Barrier into rough opening. Bottom leg must overlap first layer. Do not staple immediately below the sill/jamb corners (Fig 11.8).

8. **Installing the Window:** After the strips of Water-Resistive Barrier have been installed at the sill and jambs as shown, the window can be installed (Fig 11.9).

9. **Metal Flashing Profile:** The flashing above the window should be fabricated in the profile shown. Flashing material should be corrosion resistant and compatible with other construction materials (Fig 11.10). The length of the cap flashing must be at least as long as the top of the window and may be up to 1/2 in. (13mm) longer at each end when installed (not mandatory).

**NOTE:** Head flashing is typically the responsibility of the window/door installer not the EIFS installer unless that is clearly indicated in contract documents.



**10. Installation of Metal Flashing: VERY IMPORTANT!!** This head cap flashing must go **UNDER** the Water-Resistive Barrier, **NOT ON TOP OF IT**. If nailing flange-type (self-flashing) windows are installed, the head flange **MUST GO UNDER** the Water-Resistive Barrier as well.

**11. Installation of Track over Heads (ONLY ALLOWED ON COMBUSTIBLE CONSTRUCTION - CONTACT TECHNICAL SERVICES TO DETERMINE IF THIS IS APPROPRIATE FOR YOUR TYPE OF CONSTRUCTION):** Vented track is cut to extend 1/2 in. (13mm) past either end of the head of door or window and installed with its vertical leg **BEHIND** the StuccoWrap and 1/4 in. (6mm) to 3/8 in. (10mm) above the metal head flashing (or head of self-flashing windows) to allow drainage space. Add Flashing Membrane “bandages” at both corners. (Fig. 11.11)

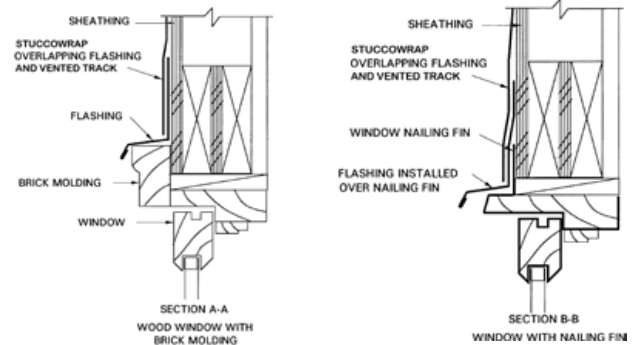

Fig. 11.11

### INSTALLING WATER-RESISTIVE BARRIER

Water-Resistive Barrier shall be free from holes or breaks other than those created by fasteners over sheathing. Apply StuccoWrap or approved equal over sheathing at all areas to receive the WaterMaster LCR system, or code compliant water-resistive barrier for LCR-GX or LCR- DM Systems in accordance with manufacturer’s installation instructions. Lap Water-Resistive Barrier over the back leg of the vented track at the bottom and at vertical edges of the system.

1. Install rolls horizontally in a shingle fashion working from bottom to top. Each succeeding course should overlap the previous course 2 in. (51mm) minimum or in accordance with manufacturer’s instructions. Parex USA suggests marking the location of the sheathing board joints on the Water-Resistive Barrier as you proceed up the wall. These markings can be used as a reference to prevent the alignment of the insulation board joints and the sheathing board joints. **NOTE:** The strips of Water-Resistive Barrier previously installed at the sill and jambs overlap the Water-Resistive Barrier below the sill for positive drainage (Fig 12.1).
2. Continue to lap each succeeding course as illustrated for positive drainage. Where vertical splices occur, lap the Water-Resistive Barrier a minimum of 6 in. (152mm). Vertical splices in the building paper should not occur within 2 in. (610mm) of window jambs. Offset vertical splices in succeeding courses by a minimum of 2 in. (610mm). **NOTE:** The succeeding courses lap over the remainder of the Water-Resistive Barrier jamb strips and the metal flashing at the head. Apply sealant at penetrations of the Water-Resistive Barrier (Other than those made by fasteners) (Fig 12.2).

**NOTE:** The steps illustrated here show how to effectively install rough opening wrapping and the window and door prior to the installation of the Water-Resistive Barrier on the main structure. If the building sequence is such that the structure can be covered with the Water-Resistive Barrier first, follow the manufacturer’s instructions for the proper sequencing and procedure to install their products at rough openings. The important fact is that the proper installation sequence is followed by all trades involved so the window or door, once installed, acts like a roof shingle and proper lapping of all three components will always shed water to the exterior naturally.

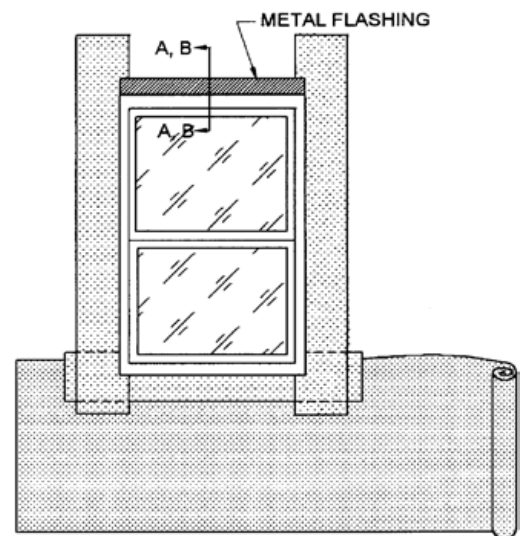

Fig. 12.1

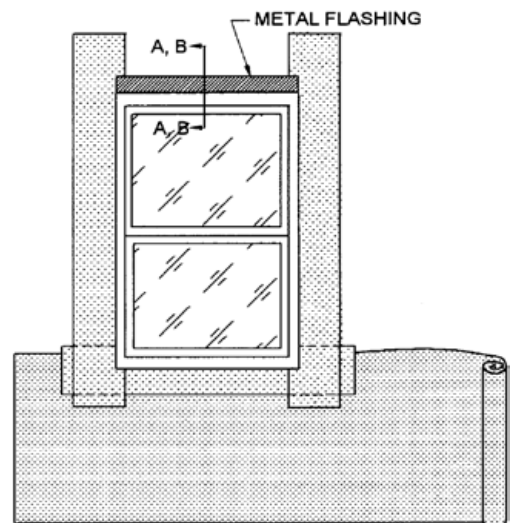
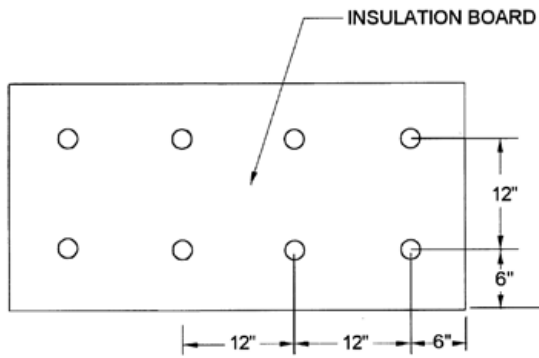
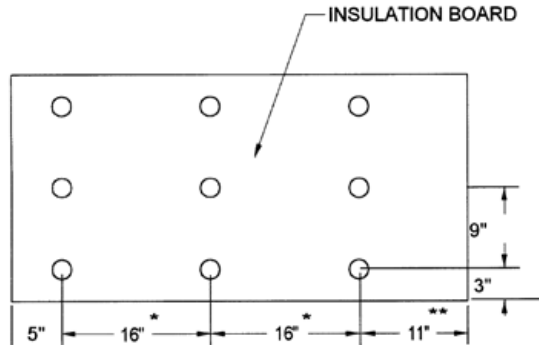

Fig. 12.2



**Fastening Pattern A**  
Structural Sheathing,  
Masonry and Concrete  
Only.



**Fastening Pattern B**  
Required for Non-Structural  
Sheathing. Optional for

Fig. 12.3

## INSTALLING PAREX USA DETAIL MESH

**Detail Mesh for Backwrapping:** Mechanically Fastened EIFS Systems terminations that will not be done with track should now have Parex USA 356 Short Detail Mesh and 369 DrainEdge stapled to the substrate at those areas (jamb, sills, soffits, etc). See Commercial Drainage Installation Section.

**NOTE:** The EPS application can now begin. The Parex USA Mechanically Fastened EIFS systems are done with standard (flat) EPS board and this system requires mechanical fastening.

When mechanical fasteners are used, Parex USA requires using EPS board that is at least 1-1/2 in. (38mm) thick to ensure proper negative wind-load resistance. Use only fasteners approved by the fastener manufacturer for use with EPS applications, follow their fastening pattern (Fig 12.3) as a minimum (or the pattern specified by a design professional) and do not overdrive the fasteners.

The rules for insulation board installation with mechanical fasteners are the same as for adhesive application. (Stagger vertical joints, don't line up EPS board joints with sheathing joints, etc.) Therefore, refer to those steps described and shown with the Standard EIFS, Mechanically Fastened EIFS, and Commercial Drainage EIFS Systems, beginning on page 4 and continuing through the finish and sealant application on page 14. If aesthetic grooves are planned for a mechanically attached project, plan ahead for fastener placement so they don't interfere with cutting accent grooves. Also, when basecoating mechanically attached projects, the fastener heads must be pre-spotted with basecoat prior to the mesh and basecoat application.

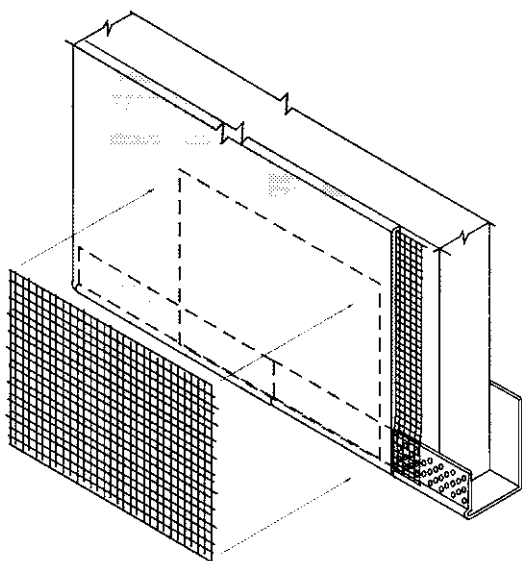

Fig. 12.4

## Basecoat Application over Track

Where ends of tracks meet, apply rectangular patches of mesh approximately 6 in. by 9 in. (15cm by 22cm) long, entered on the track joint, to provide a double layer of mesh at these locations (Fig 12.4).

Ensure that both the reinforcing mesh and the basecoat overlap the entire perforated flange of track used in the installation. This effectively closes off the insulation board edge, forming an aesthetically pleasing termination that protects the system from moisture penetration.

**Warning:** Failure to apply the reinforced basecoat as outlined above could cause cracking and/or moisture penetration at these locations.

**NOTE:** All WaterMaster systems require waterproofing of all openings prior to system application.

## 5. STEPS FOR THE COMMERCIAL DRAINAGE EIFS OVER PAREX USA WEATHERSEAL

This system is applied only over substrates listed in the Parex USA Technical Bulletin "Acceptable Substrates and Areas of Use". **NOTE: Wood sheathings may require 2 coats of WeatherSeal Spray & Roll-On or Trowel-On.** Rough openings are sealed with 396 Sheathing Tape embedded in WeatherSeal. The sheathing joints are sealed with Parex USA 396 Sheathing Tape embedded in Parex USA WeatherSeal followed by an application of Parex USA WeatherSeal over all sheathing surfaces, joints and rough openings and allowed to dry 24 hours. Standard (flat) EPS board is then adhesively attached using vertical ribbons (parallel to the 2 ft. [61cm] dimension of the EPS board) of adhesive.

### PRELIMINARY STEPS:

**Inspect the sheathing:** Inspect the sheathing application for correct fastener spacing and depth of fastener into the sheathing. Check for sheathing and framing flatness. Broken or weathered sheathing must be replaced. Gaps in sheathing greater than 1/4 in. (6mm) must be filled with any Parex USA Cementitious Basecoat & Adhesive and allowed to fully dry.

**Seal all rough openings as follows:** Windows, doors, louvers, etc. **MUST NOT BE INSTALLED** at this point.

### ROUGH OPENING TREATMENT

1. Cut Sheathing Joint tape in a length to wrap all the way into the rough opening and onto the sheathing face a minimum of 2 inches. Cut and embed as shown in (Fig 13.1).
2. Cut "bandages" to 4 in. (102mm) x 6 in. (152mm). Embed 396 Sheathing Tape into Parex USA WeatherSeal and install diagonally at sill corners as shown. Sheathing should not be visible at the corners of the rough opening (Fig 13.2).
3. Cut a piece of Parex USA 396 Sheathing Tape 8 in. (203mm) longer than the rough opening. Embed Sheathing Tape into Parex USA WeatherSeal and install on the sill and up the jambs with at least 2 in. (51mm) protruding to the outside of the opening. Make a cut at each corner to form three "flaps" (Fig 13.3).

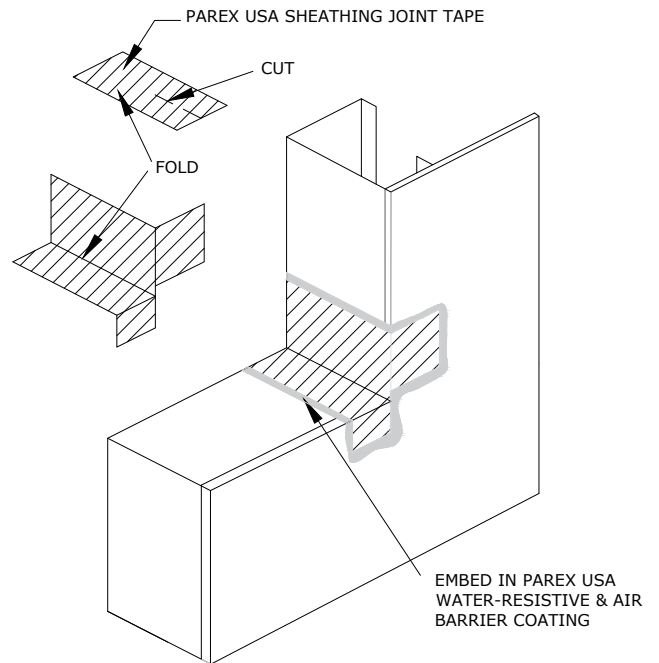

Fig. 13.1

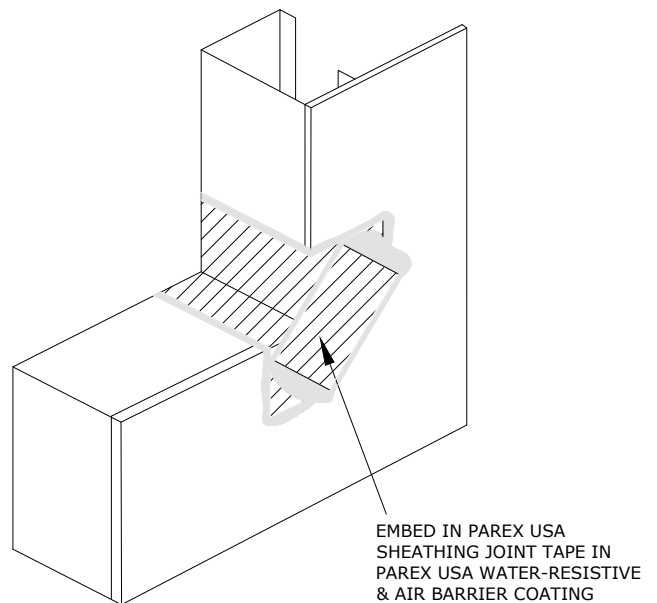

Fig. 13.2

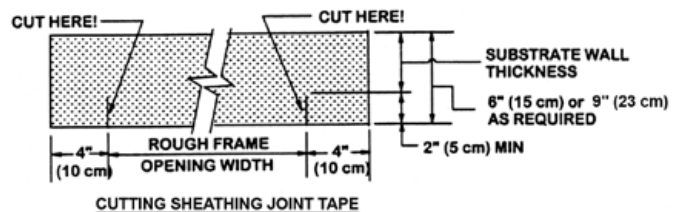

Fig. 13.3

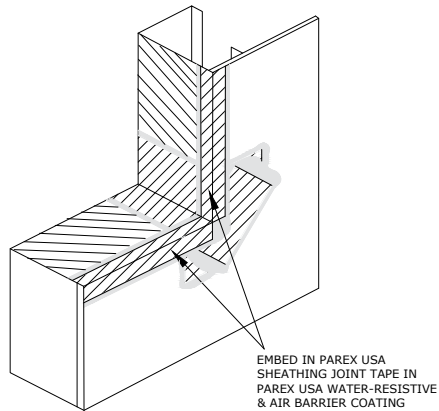

Fig. 13.4

4. Fold the bottom flap down over the sheathing. Fold the end flaps against the sheathing (Fig 13.4).
5. Repeat Step 3 for the jambs by coating the jambs with WeatherSeal and installing a piece of Sheathing joint tape to the jamb and wrapped at least 2 in. (51mm) onto the sheathing such that it laps the sill piece and continues up past the head opening at least 4 in. (102mm) (Fig 13.4).

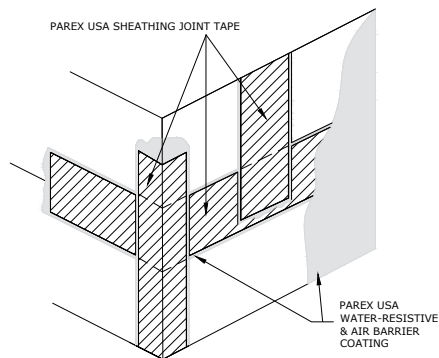

Fig. 13.5

#### Weatherproof the Sheathing Joints and Corners:

Apply WeatherSeal in minimum 5 in. (127mm) wide bands centered over sheathing joints and immediately center and embed Parex USA 396 Sheathing Tape into the wet WeatherSeal. A 4 or 6 in. (10 or 15mm) wide drywall knife works very well to adhere the 396 Sheathing Joint Tape to the wet WeatherSeal. All inside and outside corners shall be sealed in the same manner. (Fig 13.5).

Parex USA Flashing Membrane may also be used for protection of the rough openings. Primer may be required on certain substrates.

More complete details for installing Parex USA WeatherSeal can be found at [parex.com](http://parex.com), [teifs.com](http://teifs.com), [elrey.com](http://elrey.com) and [lahabrastucco.com](http://lahabrastucco.com).

## Seal the Head (Cap) Flashing of All Openings:

**NOTE:** Cap flashing is a part of self-flashing (flange-type) windows, doors, etc. so those items must be installed prior to the installation of the Parex USA 369 DrainEdge and 356 Short Detail Mesh. Other types of commercial windows, doors and AC units may need to have metal cap flashing fabricated and installed above them to provide adequate protection. The final position of the object in the opening is critical and must be determined prior to the cap flashing installation. This is typically done by others but does affect the placement of your Parex USA 369 DrainEdge and 356 Short Detail Mesh. Shop drawings, communication and coordination are necessary to accomplish this detail, as it will vary from job to job. (See Parex USA EIFS Details for options). Seal the top of the cap flashing with Parex USA Sheathing Tape embedded in WeatherSeal Spray & Roll-On or Parex USA Flashing Membrane. (Fig. 14.1).

### Parex USA WeatherSeal:

Parex USA WeatherSeal is applied over all previously coated rough openings, joint treatments, corners and sheathing surfaces. Spray applications require back rolling using a 1-1/4 in. (31mm) nap roller and allowed to dry. Parex USA WeatherSeal Trowel-On is troweled over all sheathing surfaces in accordance with the product data sheet. (Fig 14.2).

### 369 DrainEdge and 356 Short Detail Mesh At The Cap Flashing Of ALL Openings:

Install Parex USA 369 DrainEdge 1/4 in. (6mm) beyond both ends of the head, and Detail Mesh (1 in. (25mm) beyond both ends of the head of windows, doors, and AC units) above head of cap flashing. The Parex USA 369 DrainEdge Strip is installed first with the third row of holes from the bottom at the corner of the cap flashing. This should be attached with corrosion resistant staples. 356 Short Detail Mesh is then installed over the Parex USA 369 DrainEdge with corrosion resistant staples (Fig 14.1).

For Non-combustible construction, one ribbon or adhesive is installed horizontally as shown in Figure 14.1.

### Detail Mesh for Backwrapping:

The backwrap mesh is to be attached to the substrate by adhesive or corrosion resistant staples (Fig 14.4).

The preliminary steps are now complete. The remaining steps are to properly detail the heads of all opening, and then install the insulation layer.

### EPS Board Installation:

The EPS board application can now begin. If any aesthetic grooves are to be cut in the EPS they should not line up with the EPS board joints.

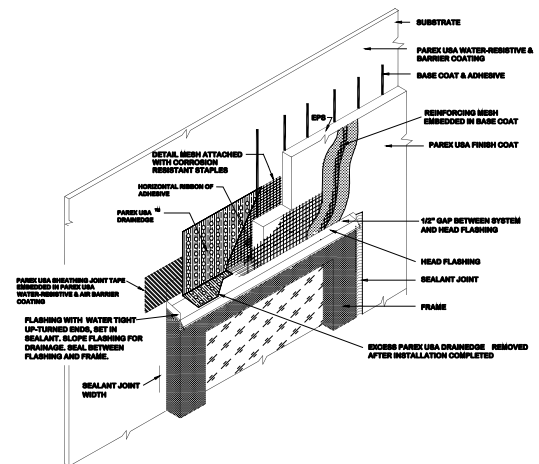

Fig. 14.1

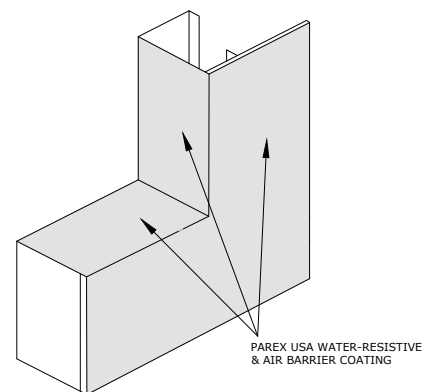

Fig. 14.2

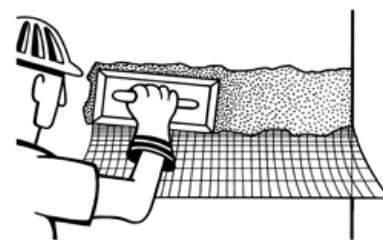

Fig. 14.4

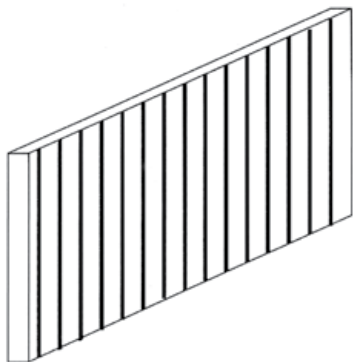

Fig. 15.1

## INSTALLING THE INSULATION BOARD ON COMMERCIAL DRAINAGE EIFS PROJECTS

The previous section of this guide has shown the preliminary tasks of wrapping rough openings, backwrapping, installing tracks, water-resistive barriers and flashing required for the different Parex USA Commercial Drainage EIFS Systems. One system requires mechanical attachment of the EPS board and the other, liquid applied barrier system, makes use of adhesive attachment. The layout and application of the EPS board is the same for each system even though the attachment method may differ. Information regarding those differences is listed here:

### **When the adhesive is used in the WaterMaster System:**

The ribbons of adhesive must be made with a 1/2 x 1/2 x 2 in. (13 x 13 x 51mm) spacing U-notched trowel. The ribbons of adhesive must run vertically when positioned on the substrate (parallel to the 2 ft. [61cm] board dimension). (Fig 15.1)

The rules for insulation board installation have been described and shown with the Standard System, beginning on page 4 and continuing through the finish and sealant application on page 15.



# PAREXUSA

**PAREXUSA**  
www.parexusa.com

**Corporate Office**

Parex USA, Inc.  
4125 E. La Palma Ave., Suite 250  
Anaheim, CA 92807  
(866) 516-0061  
Tech Support: (800) 226-2424

**Facilities**

French Camp, CA  
North Hollywood, CA  
Riverside, CA  
Colorado Springs, CO  
Haines City, FL

Duluth, GA  
Redan, GA  
Albuquerque, NM  
Allentown, PA  
San Antonio, TX

